

MSDTM IGNITION INSTALLATION INSTRUCTIONS

MSD Crankshaft Hub Installation/Removal Tool, PN 7992 For MSD Sprint Car Crank Trigger Systems

Parts Included:

- 1 - Spacer
- 3 - Thrust Bearing w/Washers
- 1 - Threaded Collar
- 1 - Puller Flange
- 1 - Threaded Stud and Nut
- 1 - Flange Nut and Washer

- 1 - Degree Wheel Adapter
- 4 - Socket Head Cap Screws

Required, Not Included:

- 1 - Crankshaft Centering Bolt
- 1 - Moly or EP Lubricant

This Tool is designed to install and remove the crankshaft hub of MSD's Sprint Car Crank Trigger Kits. The hub must be installed with a 0.001" - 0.0015" press fit on the crankshaft. An adapter is also supplied that can easily be machined to accept a degree wheel.

Figure 1 Installing the Crank Hub

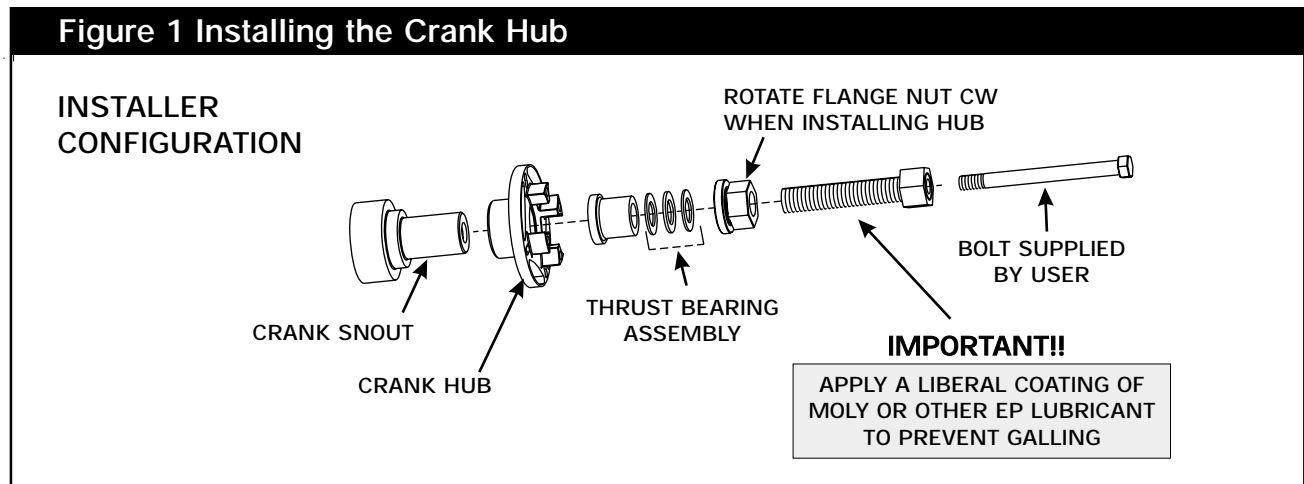

Figure 2 Removing the Crank Hub

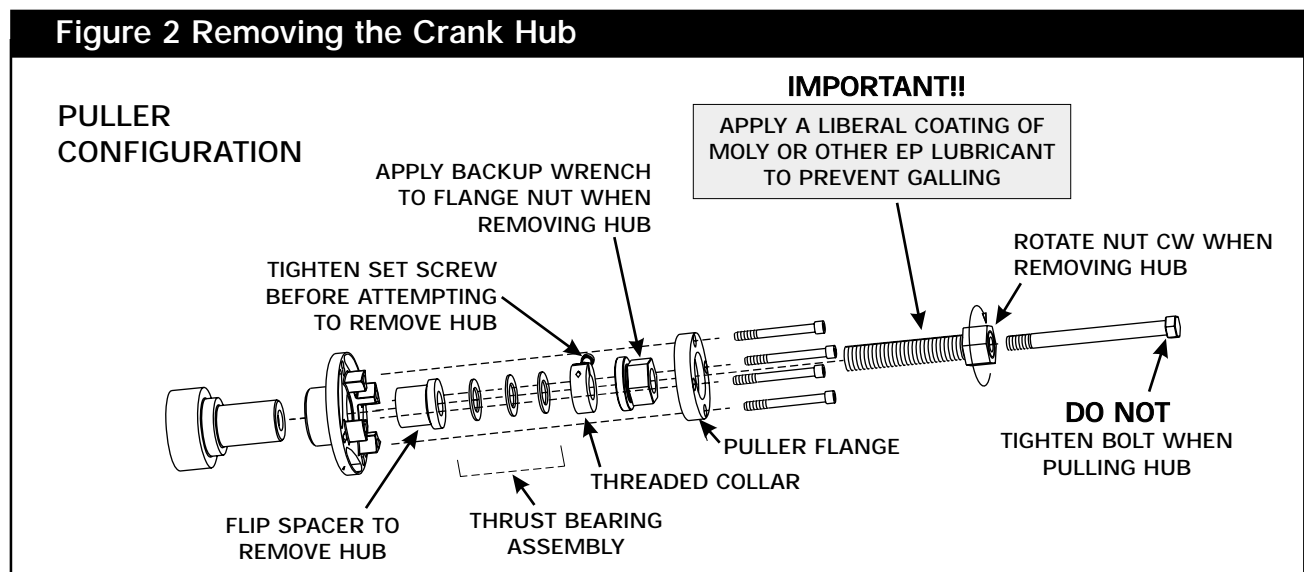
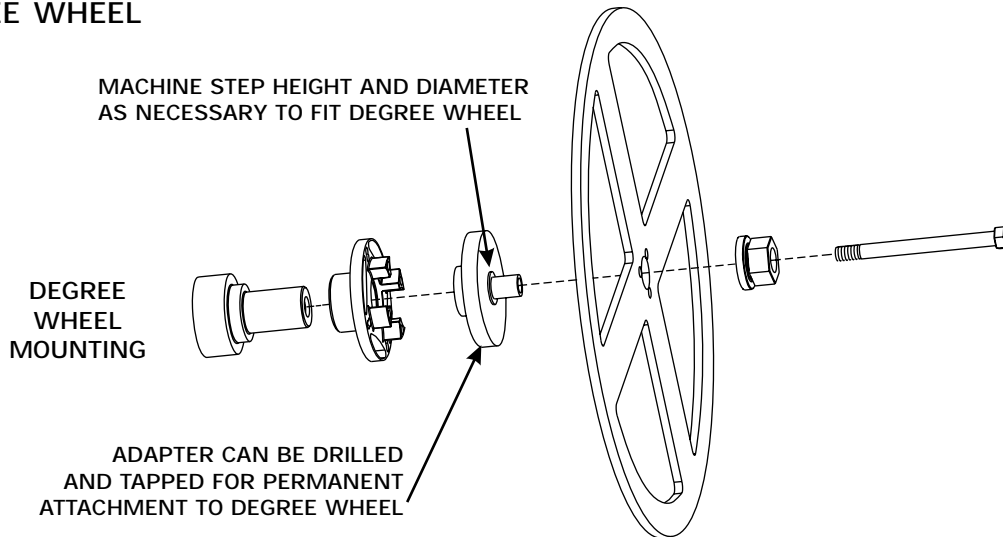

Figure 3 Installing a Degree Wheel

MOUNTING A DEGREE WHEEL



Service

In case of malfunction, this MSD component will be repaired free of charge according to the terms of the warranty. When returning MSD components for service, Proof of Purchase must be supplied for warranty verification. After the warranty period has expired, repair service is charged based on a minimum and maximum charge.

Send the unit prepaid with proof of purchase to the attention of: **Customer Service Department, Autotronic Controls Corporation, 12120 Esther Lama, Suite 114, El Paso, Texas 79936.**

When returning the unit for repair, leave all wires at the length in which you have them installed. Be sure to include a detailed account of any problems experienced, and what components and accessories are installed on the vehicle.

The repaired unit will be returned as soon as possible after receipt, COD for any charges. (Ground shipping is covered by warranty). All units are returned regular UPS unless otherwise noted. For more information, call the MSD Customer Service Line (915) 855-7123. MSD technicians are available from 8:00 a.m. to 5:00 p.m. Monday - Friday (mountain time).

Limited Warranty

Autotronic Controls Corporation warrants MSD Ignition products to be free from defects in material and workmanship under normal use and if properly installed for a period of one year from date of purchase. If found to be defective as mentioned above, it will be replaced or repaired if returned prepaid along with proof of date of purchase. This shall constitute the sole remedy of the purchaser and the sole liability of Autotronic Controls Corporation. To the extent permitted by law, the foregoing is exclusive and in lieu of all other warranties or representations whether expressed or implied, including any implied warranty of merchantability or fitness. In no event shall Autotronic Controls Corporation be liable for special or consequential damages.