

MSD 8971 Dual Mag Timing Controller
Operation, Programming and Diagnostics
6 January 2004

The 8971 timing controller is programmed only with the MSD 7570 Graphics editor, which is a handheld device with an LCD touch screen. All the timing data is entered by touching the LCD screen to select an edit function and then moving the selected data point by dragging it on the screen or by touching the UP, Down, Left or Right screen buttons. See the figures illustrating the various LCD edit screens for the user selectable functions.

The 8971 timing controller allows the user to program a timing retard curve with from 1 to 30 data points. These data points can be moved in a range from 0 to 6 seconds, in .05 second increments and with an ignition timing retard value of 0 to 30 degrees in .5 degree increments. Also the user can program a Pedal Lift feature, which allows three values to be programmed, Pedal degrees, Pedal Ramp, and Pedal Inhibit. The Pedal degree value is selected to cause the ignition timing to retard to the Pedal Degree value when the throttle is lifted which deactivates the dark blue wire connected to the wide-open-throttle switch. The Pedal degree value is programmable from 0 to 30 degrees in .5-degree increments. The Pedal Ramp is programmed to ramp the ignition timing from the Pedal degree value to the elapsed timing curve so that the ignition retard is smoothly ramped back to the curve retard value. The Pedal Ramp value is programmable from 0 to 2.50-seconds in .01-second increments. The Pedal Inhibit value is programmable to disable or inhibit the Pedal Lift Retard until the Pedal Inhibit time has elapsed from the launch, when the WOT switch was activated to begin the retard curve timer. The Pedal Inhibit function allows the 8971 to ignore pedal lifts during the programmed time from launch so that the retard curve will be in full authority during the programmed Pedal Inhibit time and then allow the Pedal Degree value to override the timing curve when the driver lifts the throttle. This feature allows the driver to pedal the car off the line with no pedal lift retard until the desired programmed time after the launch.

Note: The wide-open throttle switch must be a switch activated by sensing the pedal movements preferably mounted near the top of the throttle pedal. This switch must be deactivated quickly when the throttle is lifted and reactivate quickly when the throttle is returned to full throttle. *An air activated switch must not be used to properly activate the dark blue launch wire! Use only a high quality microswitch such as the type found on the ProStock cars clutch switch.*

The Reset wire input is a momentary switch that should be activated before the launch, which then will select the first retard timing data point in the retard curve. When the 8971 is properly reset the two red LED's on the 8971 end panel will illuminate and stay illuminated until the Launch wire is activated at which time the two red LED's turn off and the two green LED's illuminate while the WOT switch is activated to start the timing retard timer. The two green LED's will blink rapidly when the WOT switch is deactivated during a pedal lift even though the retard timer still runs. If the reset switch is activated any time after a valid launch sequence the retard timer is reset and ignition

timing reverts to the first data point in the retard curve. If an air activated switch is used to activate the white/blue-reset wire it must deactivate before the dark blue launch wire is activated to start the retard curve timer. Some air activated switches may take over a second or more once activated before they deactivate due to pressure hysteresis and need to be thoroughly evaluated for the reset function of the 8971, which should be a momentary activation of the reset input.

The 8971 has two outputs for remotely mounted LED indicators to indicate Reset and WOT/Run modes of operation. The Red LED's on the 8971-end panel are summed for the remote Red LED indicator to indicate that both of the 8971 channels properly reset when the reset input was activated. If any alert codes are blinking on the end panel red LED's the remote Red indicator LED will not show steady reset illumination. The alert codes are a series of blinks to indicate an improper operation of the 8971 timing controller.

These blink codes on the end panel red LED's are:

2 blinks, pause, repeat-----TCD event has been detected and TCD timer is greater than 0 hours

3 blinks, pause, repeat-----Mag-pickup input has been lost on the respective channel

4 blinks, pause, repeat-----Mag-pickup offset is=>5.0 degrees

Note: If two or more alerts are active then the blink codes will follow one after another and then repeat the sequence.

The green LED's on the end panel and green remote LED will not illuminate unless the 8971 has been reset first to begin a correct launch sequence.

When a Mag-pickup is lost the 8971 counts this as a single lost Mag-input event and stores the MisMagA and MisMagB counters in the 8971 memory. When the 7570 is connected to the 8971 after a run the MisMag counters will be displayed indicating if either of the mag-input signals were lost during the run. The MisMag counters will count to a maximum of 0-255 and can be reset by pressing the Check screen button and then the Reset Mag Cnt screen button on the 7570 LCD.

If a TCD event is detected by the 8971 the TCD timer will be loaded with 24.0 Hrs and displayed on the 7570 LCD screen. The 8971 can be reset only with a NHRA KEY or the timer will count down with power applied in 24 hours, at which time the red LED's will stop blinking the TCD alert code. If the 8971 is reset with the NHRA key, the reset timer will be loaded and display a value of Rst 24.0 Hrs on the 7570 LCD screen. This timer counts down while power is applied to the 8971 and will take 24 hours to count down to 00.0 hrs. This is to give an indication that the 8971 has been reset by an NHRA official.

When setting the mag-pickups the timing should be set as close as possible for the same ignition timing or as close to 0 degrees difference between the two pickups. The phase difference is displayed on the 7570 LCD when connected to the 8971 with the engine running. The phase difference of the two pickups are displayed from -9.9 to +9.9 degrees in .1-degree increments. The bottom left message line of the LCD screen displays several monitored items from the 8971, which are:

8971 Monitor Messages:

MagDeg-0.0-----+9.9 to -9.9 Deg. .1Deg increments

MisMagA 000----0 to 255 only displayed if >0

MisMagB 000----0 to 255 only displayed if >0

Dist-----indicates the type of mag-pickup input as a distributor reluctor

Crank-----indicates the type of mag-pickup input as a crank trigger

The lower right message line on the 7570 LCD screen displays warning and alert messages from the 8971 timing controller while it is operating or the PC.

8971 Warning Messages:

TCDA 00.0 Hrs----0-24 Hours, in .1 hour increments displayed if >0

TCDB 00.0 Hrs----0-24 Hours, in .1 hour increments displayed if >0

RstA 00.0 Hrs-----0-24 Hours, in .1 hour increments displayed if >0

RstB 00.0 Hrs-----0-24 Hours, in .1 hour increments displayed if >0

MagDeg-7.2-----Maginput Offset >=5Deg

Lost MagA-----Lost MagA input

Lost MagB-----Lost MagB input

8971 Alert Messages:

Low Battery-----indicates the 7570 internal battery needs recharging, less than 20 minutes of operating time remain

Verify Error-----indicates that a file move operation was not successful or data is mismatched from the 7570 screen data

No Reply A-----indicates that the channel A microcontroller of the 8971 is not communicating properly with the 7570

No Reply B-----indicates that the channel B microcontroller of the 8971 is not communicating properly with the 7570

No Reply PC-----indicates that the PC is not communicating properly with the 7570

Loop Back-----7570 Com port test

File Compare----indicates that there is a mismatch of data on the 7570 screen and the PC or 8971 when the data is transferred or verified

Programming

Using the 7570 Graphic Editor the 8971 and other future products can be programmed without the need of a PC or Laptop computer. The 7570 can be connected to a PC to save the 6 files to the computer for archiving or printing out a hardcopy of the files saved in the 7570 EEPROM memory. Using the MSD GraphSave software the 7570 can move a single file at a time to or from the 7570 LCD screen to or from the PC screen. The GraphSave software allows the user to save the timing curve and data files and notes on the PC or retrieve the previously saved files from the PC to loaded in the 7570, which can then be loaded in the 8971 timing controller. Future versions of the MSD GraphSave software will allow the timing curves and data to be edited on the PC.

The programming of the 8971 begins by pressing the rocker power switch to the ON position on the 7570 Graphic Editor, note the file can be edited and saved in the 8971, 6 files, to be later loaded into the 8971 timing controller. When the 7570 is first powered ON the opening screen appears which allows the product type to be selected for programming. The 7570 version 1 only allows the 8971 to be selected by pressing the 8971 screen button or allowing the 7570 to default to this product. The 7570 backlight is turned on for a few seconds at power ON and will go off after about 5 seconds, when the product default occurs or after 15 seconds if the 8971-screen button is pressed. To turn the Back Light on again, press the Back Lite screen button in the lower left corner of the LCD screen. If the screen is not sensing any movements of buttons pressed the backlight will turn off after 15 seconds to conserve battery energy. If the Low Battery indicator message appears in the lower right message area, then the battery needs recharging indicating there is limited operating time remaining. Typically when the Low Battery indicator first displays the 7570 will have up to 15 minutes or more of operating time remaining if the back light is not turned on, and may be less than 5 minutes with the back light on. When the 7570 power is turned on the LCD will display the 7570 version# in the upper right corner. The 7570 can be returned to be factory reprogrammed for future product support for new features. When the opening screen times out the main screen is displayed which will look like the following illustration. Note that at the bottom LCD screen center the connected product and version number will be displayed, if no product is connected to the 8971 this area of the LCD screen will be blank.

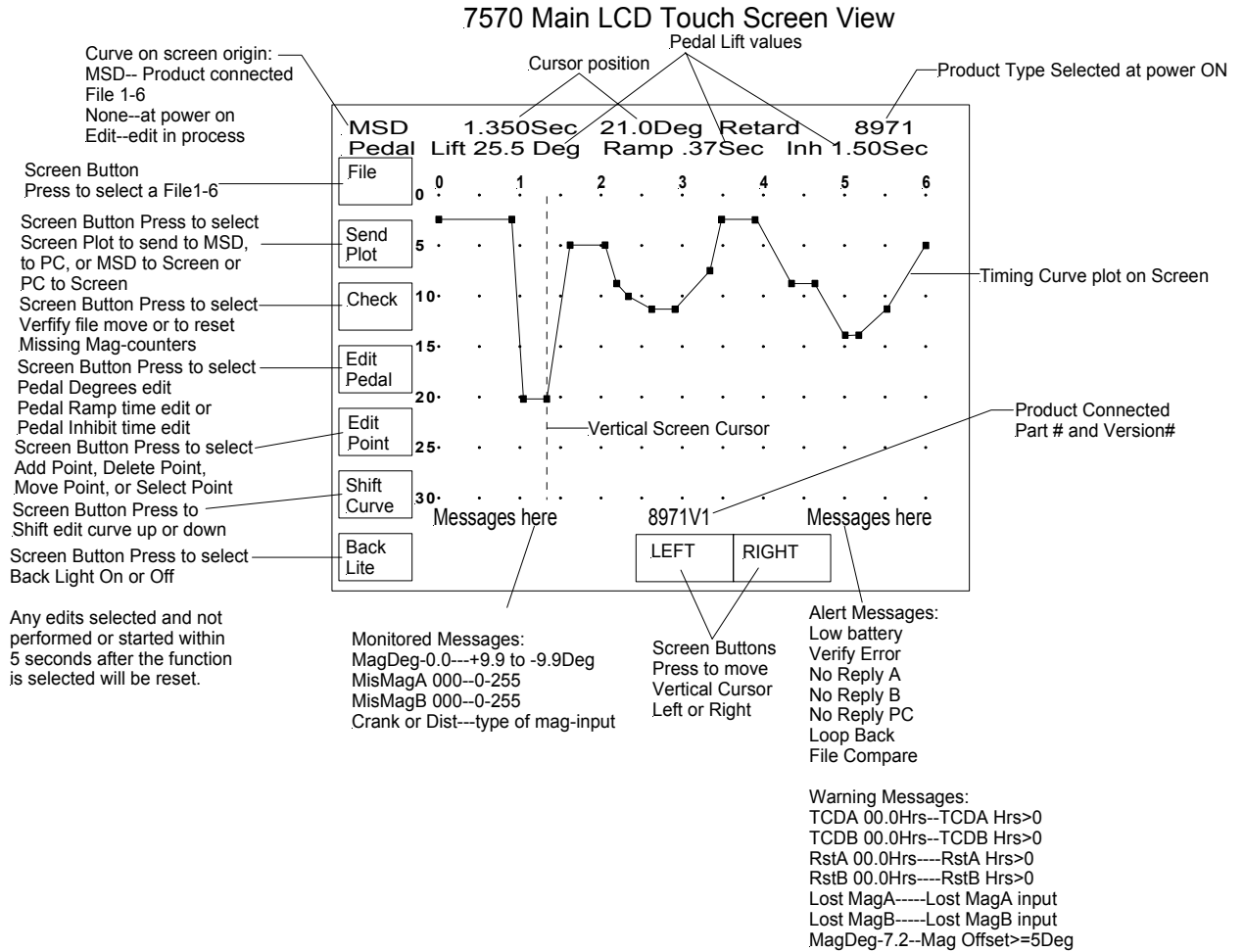

The 7570 LCD screen is illustrated above showing the Main screen with an 8971V1 connected with power on. At power on the upper left text line will display—None—indicating no curve has been loaded to the LCD screen. A vertical cursor can be moved across the screen to view the retard degrees and time at the current cursor position by touching the screen and dragging the cursor or pressing the Left and Right screen buttons. When the Left or Right screen buttons are pressed the cursor will move slowly at .05 seconds/move then move more aggressively the longer the button is pressed to allow fast relocation of the cursor from one edge of the screen to the other. Note the cursor forms a cross hair when the screen is pressed in the retard graph area, indicating the present selected position. Once the screen touch is lifted the cursor will remain at the current position and the time and retard values will be displayed on the top line of the LCD.

To begin a timing retard curve from scratch press the Edit Point button and then Add Point button. Next touch the screen where the point is desired or move the cursor using the Left, Right, Up or Down buttons to position the cursor at the desired time and degrees of retard and then press ENTER. The LCD will display a new point at the cursor position and draw a timing retard curve or line between the first point and next point. The last point is always a horizontal line from the last point to 6 seconds on the graph. Note that

the ignition timing at 6 seconds will remain beyond 6 seconds until the 8971 is powered off or reset. Once a screen edit has begun, the upper left corner of the LCD displays -- Edit—to indicate the data on the screen is being edited and is not in a file or product yet. See the screen illustration below for the Edit Point Screen choices.

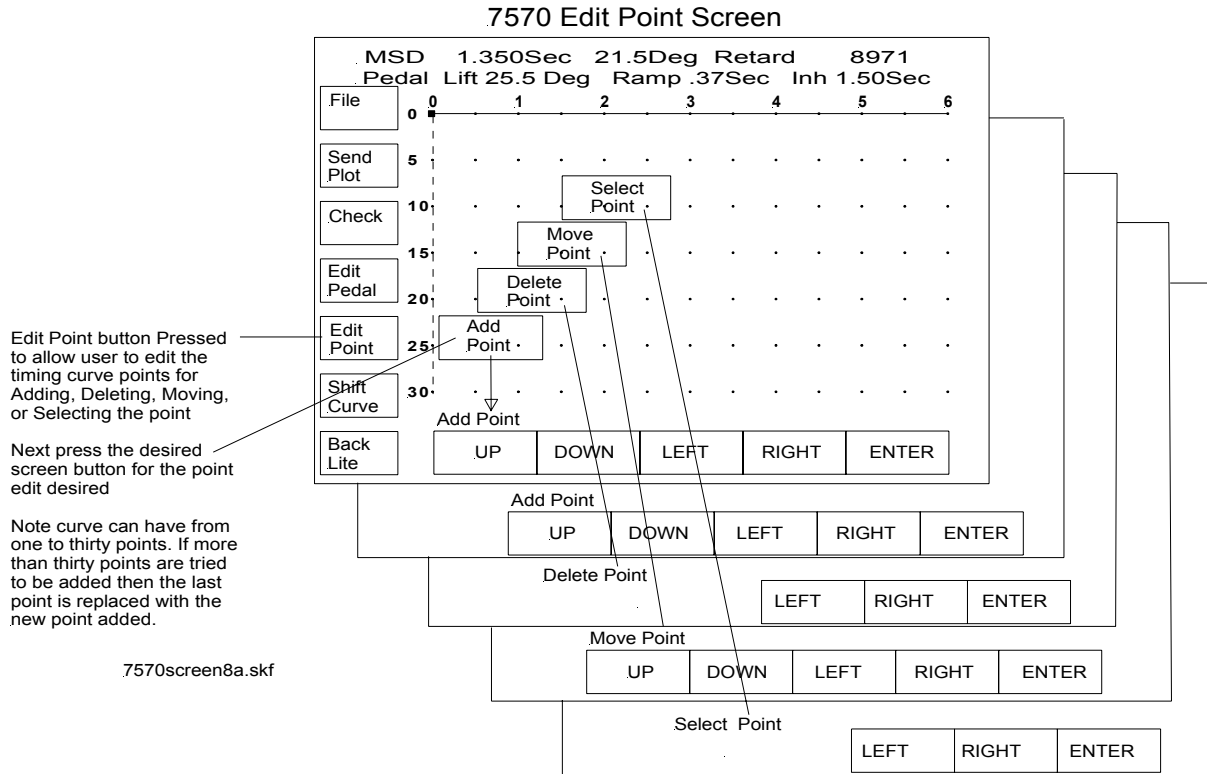

The Select Point is pressed to allow the user to select a point on the curve without moving it until desired. The Select Point can be used by touching the screen close to the point you wish to edit or by pressing the Left or Right screen buttons which will move the cursor to the next point in the direction chosen. Once the point is selected press the ENTER button and the screen then automatically changes to the Move Point edit screen to allow the user to move the selected point by then pressing the respective direction buttons. If at any time an edit is not desired do not touch the screen buttons or graph and the current pending edit will time out after 5 seconds and will return the screen to the main screen display. The ENTER button speeds up the edit to the next sequence in the Edit function. As can be seen in the above screen the Edit Point button allows the user to select one of 4 edit functions, Add Point, Delete Point, Move Point, and Select Point. Again the Select Point can be pressed prior to any other edit to move the cursor to the point or place on the screen to add, delete or move a point. Note a timing retard curve has a minimum of 1 point and a maximum of 30 points. All ignition timing is interpolated to the nearest 1/10-Degree between points every millisecond for very smooth timing between points.

Shift Curve is used to shift an entire retard curve up or down. By pressing the Shift Curve button the Shift curve screen is shown below with an Up, Down and ENTER buttons. Also a value is displayed which indicates how far the curve is being shifted from the previous position. If any points are at zero the timing curve cannot be shifted up further and likewise if any points are at 30 degrees, the curve cannot be shifted down further. See the illustration below for the Shift Curve screen.

7570 Shift Curve Screen

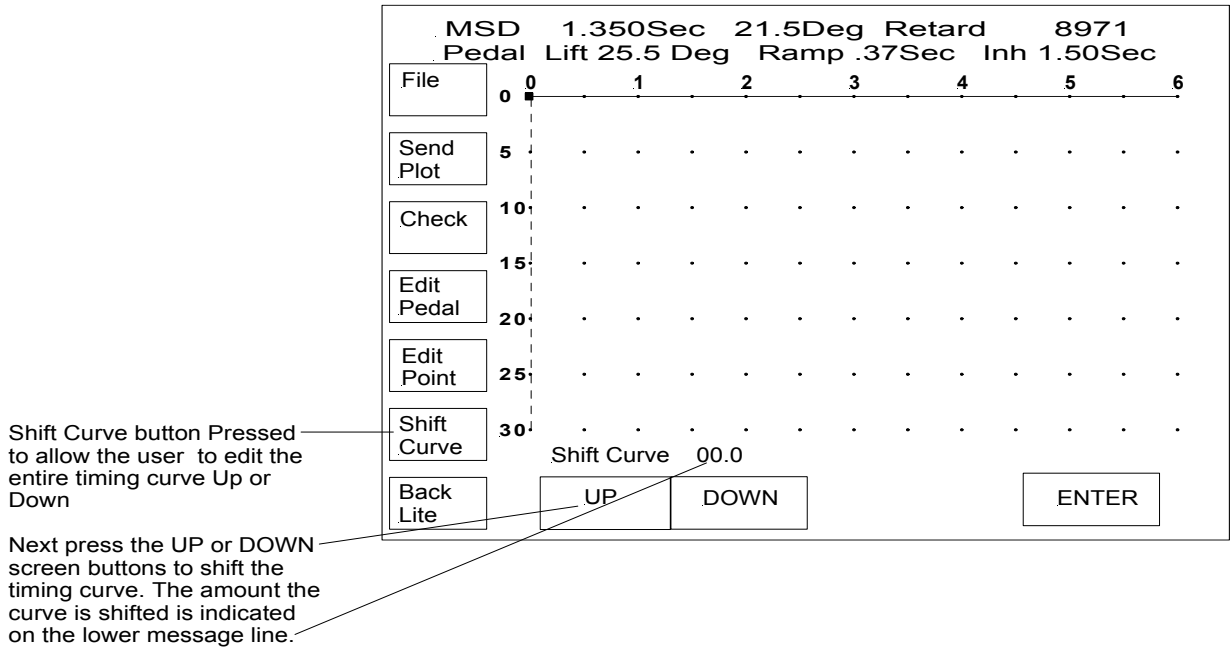

Note that once any point is at Zero or 30 degrees the curve can not be shifted any further.

7570screen9.skf

Pressing the Edit Pedal button will allow the user select Pedal Degrees, Pedal Ramp, or Pedal Inhibit. Press the Pedal Degree button to edit the Pedal Lift degree retard value with the Up or Down buttons. Press the Pedal Ramp button to edit the Pedal Ramp time in seconds for the pedal retard function. Press the Pedal Inhibit button to edit the pedal inhibit time from launch until a pedal lift retard is allowed. See the Edit Pedal screen below. All of the Pedal Lift retard values are seen on the second text line at the top of the LCD screen.

7570 Edit Pedal Screen

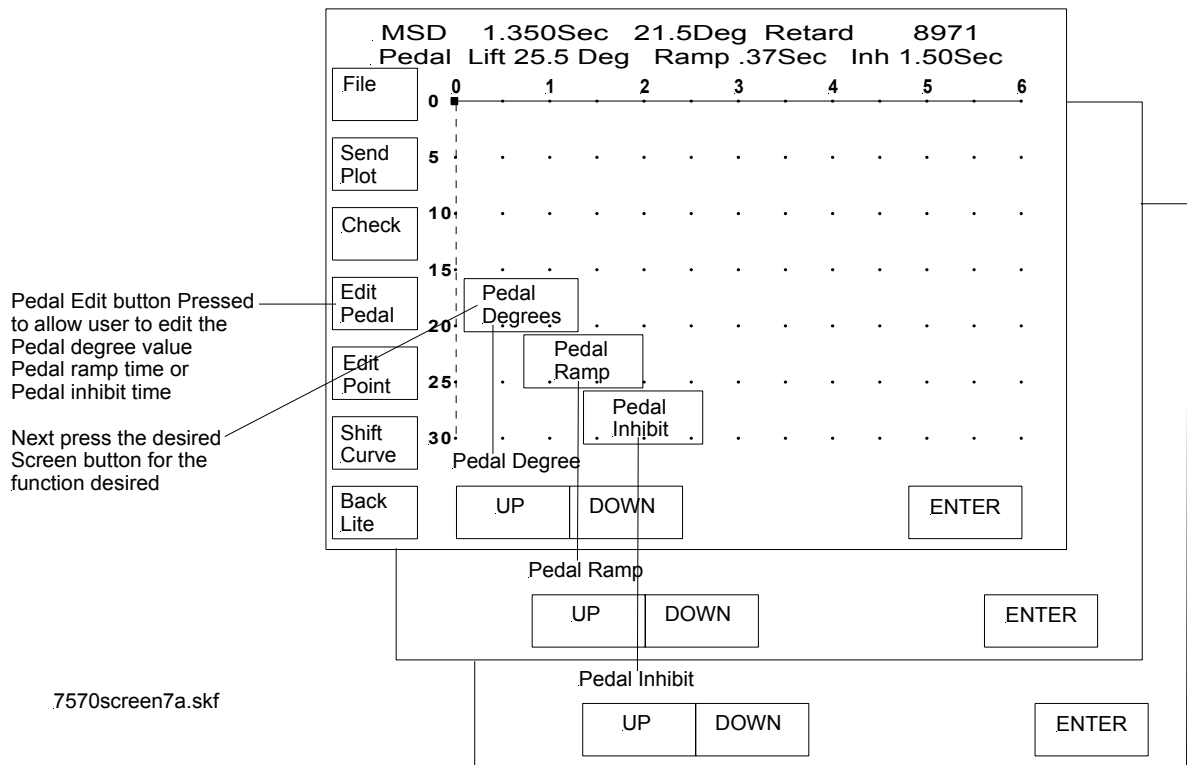

After the timing retard curve and Pedal Lift values have been edited the screen should next be saved to a file in the 7570, which can be saved into one of 6 files for later retrieval to load into the 8971 or PC. Press the File button to display the File screen and then select a file to save the present screen to. Begin with Save1 for the first file. After the Save1 button is pressed the present screen is now saved in the 7570 EEPROM and will remain there even if power is now turned off. To recall a previously saved file from memory in the 7570, press File and then # To Screen button to bring the selected file from memory to the LCD screen. See the screen illustration below of the File screen.

7570 File Save/Move Screen

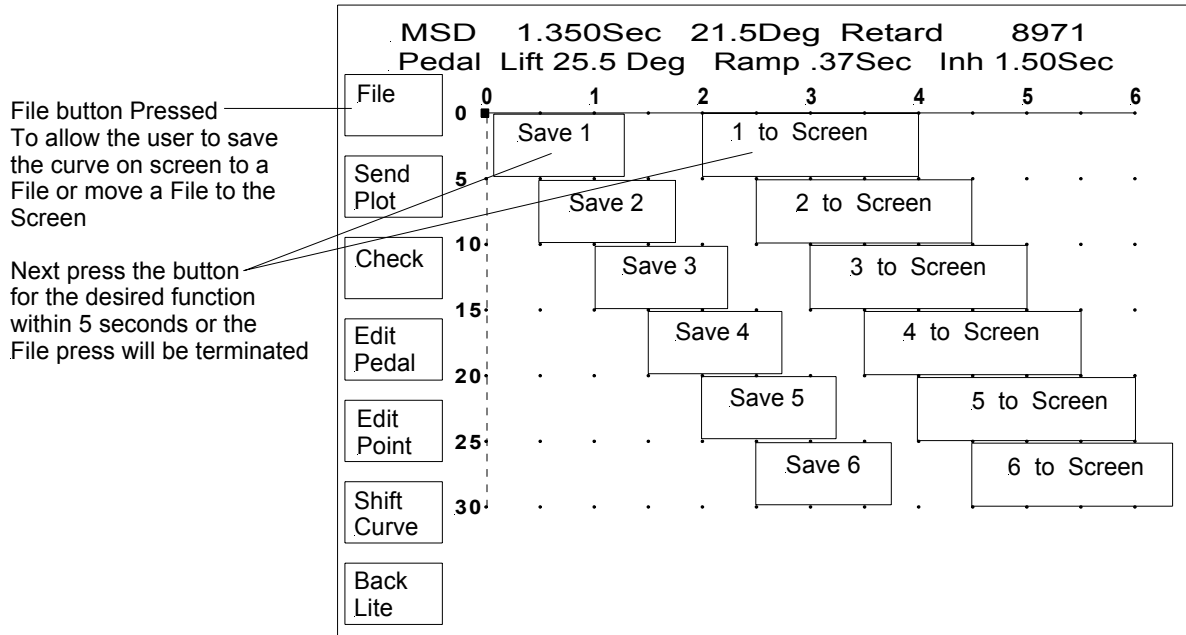

The user can store 6 different files of timing curves and Pedal Lift values that can be loaded into the PC or 8971 timing control in less than 1 second. After the File save has been done the upper left corner of the LCD screen displays—File#-- the number of the file that the data was saved to.

To Load a file from the 7570 to the 8971 first retrieve the file from memory from the File screen an selecting the file, pressing # To Screen. After the file appears on the screen it can be transferred to the 8971 pressing the Send Plot button.

When the Send Plot button is pressed the Send Plot screen is displayed with 4 buttons, To MSD, To PC, MSD To Screen, and PC to Screen. These buttons allow the user to select the direction of the data transfer between the device connected to the 7570. To load the selected file or the file that is presently on the LCD screen power must be turned on to the 8971 and communications established as indicated by the part number 8971V1 appearing in the center bottom area of the 7570 LCD screen. Press the Send Plot button and then press the button--To MSD—to transfer the file on the LCD screen to the MSD 8971 timing control. The upper left corner of the LCD screen will display—MSD—indicating the screen data now matches the 8971 product data. If the transfer was successful the lower left message line will display Verify OK, indicating that the file was transferred to both channels of the 8971 and verified to be complete. If an alert message displays in the lower right message area of the LCD screen such as No Reply A, No Reply B or Verify Error, then the transfer was not successful. The No Reply message could mean that the cable was not attached good between the 7570 and 8971 or that power was not maintained on the 8971 timing control during the transfer. A Verify Error means that there was a data mismatch from the screen data and what was received back from the 8971 during the verification check. The Verification Error could mean that the data was corrupted during the send or receive during the data transfer for reasons due to noise,

excessively long cable, poor connections on both or either cable end, low battery in 7570 or power to the 8971 was corrupted. Check for any of these conditions and resend plot-data until Verify OK is displayed. See the illustrated Send Plot screen below.

7570 Send Plot Screen

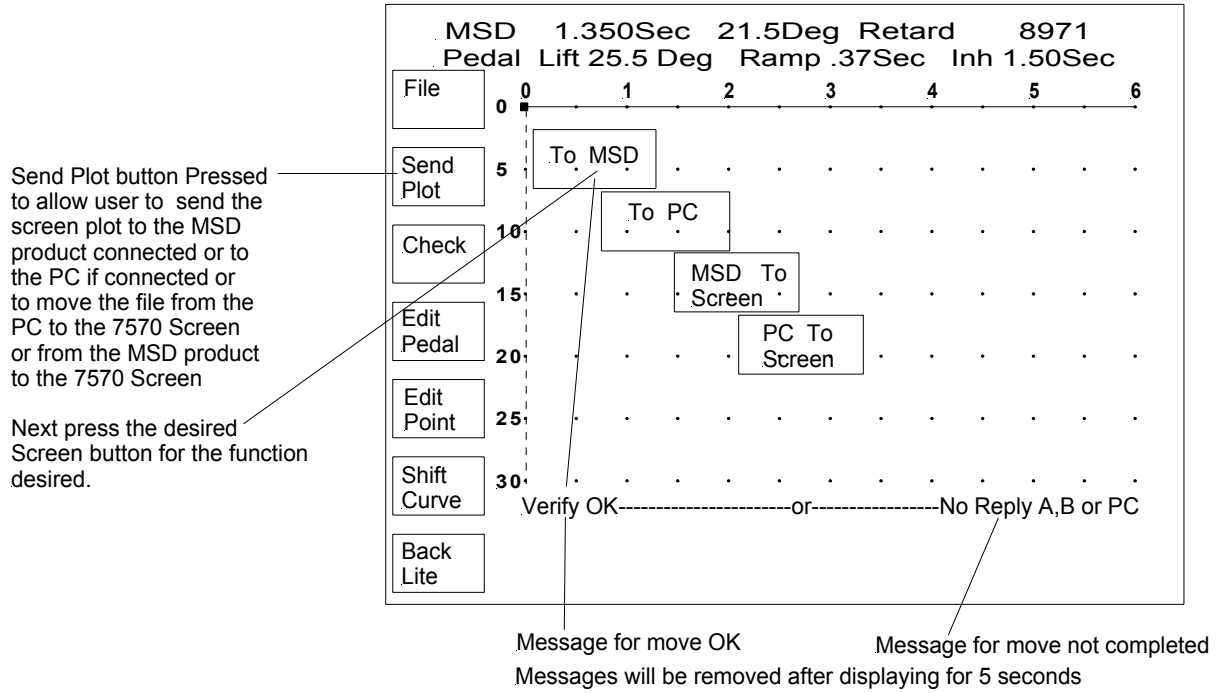

Other checks can be performed to verify that the data on the screen is the same data in the 8971 timing controller by pressing the Check button. The Check function is used to verify the last move operation or compare the present LCD screen data with the file data of the 8971 or PC screen. When the Check button is pressed the Check screen is displayed to allow the user to select Verify Move or Reset MagCnt. When the Verify Move button is pressed the 7570 will verify that the last move operation, which could be a file save, file move to screen, or transfer to the 8971 or PC was successful and the data matches the data on the LCD screen. An Alert message is displayed if the data is mismatched or there was no reply from the selected device to communicate with. See the illustrated Check Screen below.

7570 Check Screen

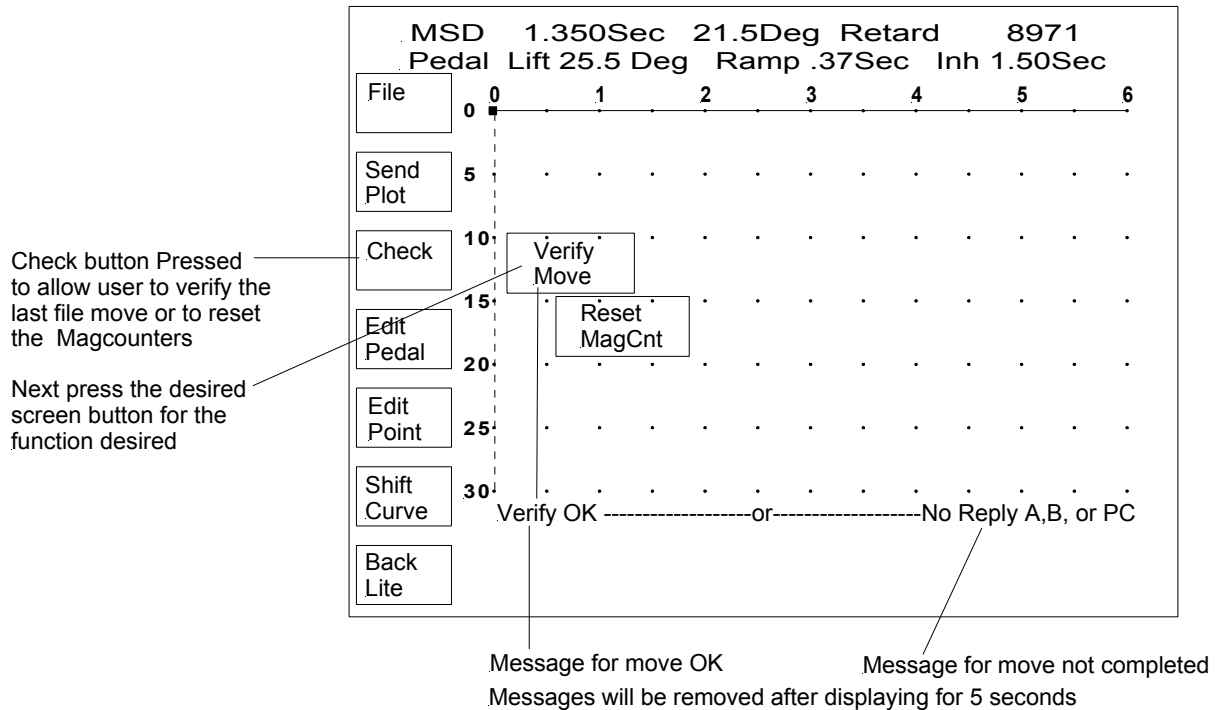

The 7570 can be connected to a PC or Laptop for saving files transferred from the 7570 or allowing files to be transferred from the PC to the 7570 using the MSD GraphSave software operating on any Windows operating system under Windows 95,98,XP, NT, 2000, or Me. All transfers are under the control of the 7570, in that the 7570 will initiate all file transfers to and from the PC screen to the 7570 screen, and then the 7570 screen data maybe saved to a file or MSD product such as the 8971. Only one device either the PC or the 8971 product can be connected to the 7570 at a time. Because only one shared Com port is available for communications, only one device may be connected at any time. The PC allows for printing the timing curve data along with the Pedal data values and any notes. The file must be opened on the PC before a transfer from the PC to the 7570 by pressing the Send To PC button; otherwise a zero data file will be transferred. See the Help file for the 8971V1 in the MSD GraphSave program for more information on use of the PC with the 8971 and 7570 Graphic Editor.

Diagnostics

The 7570 can be used to help diagnose several problems found in the 8971, which may include bad or intermittent mag-pickups, improperly phased mag-pickups, missing mag-pickup signals, traction control detection, or communication errors to the 8971 or PC. The MisMag counter will detect when the mag-input signal is missing and count the event as one event each time the mag-input signal is lost for each mag-input. The MisMag counter is saved in the 8971 EEPROM so that after a run down the track or even with the engine running in the pits if either mag-pickup fails to produce a continuous input signal the lost mag signal is counted and updates the 8971 memory to be monitored

by the 7570 while the engine is running or after the run. The MisMag counter helps to diagnose a failing pickup that might otherwise only happen going down the track and not be failing in the pits. Pressing the Check button and then the Reset Mag Cnt button to reset both MisMag counters will reset the MisMag counter; this is done with power on to the 8971 and the Com cable connected. Since the 8971 has two mag-input channels each microcontroller in the 8971 is constantly comparing the quality of both mag-input signals to determine if one has gone bad by dropping out or bad by providing a noisy signal caused by a loose connector or open pickup as well as a shorted pickup and rejects the bad pickup within one ignition cycle without letting the bad signal cause miss-triggering of the magneto. The bad pickup is constantly being monitored to re-qualify for an acceptable input signal if it remains in the proper phase relationship to the remaining good pickup for a minimum number of ignition cycles. Even when a bad pickup signal is found, both magneto trigger outputs use the remaining good pickup signal. Both magnetos will always trigger simultaneously from the most retarded pickup of the two input signals, even when the pickups are slightly staggered and one pickup is lost the 8971 will maintain the same ignition timing that was provided before the lost pickup.

The TCD functions to detect a modified mag-input signal, which may occur when a traction control device is connected to the 8971 timing controller. The action of the traction control device is very uniquely sensed by the hardware and firmware in the two microcontrollers of the 8971. A shorted or open mag-input will not cause a TCD event to be set in the 8971 because of the algorithms used to sense the difference between a bad pickup and a traction control device modifying the mag-input signal. The 8971 will set the TCD counter to 24.0 Hrs in memory when a valid TCD event is detected and requires that the 8971 be powered on for 24 hours to count down to reset the TCD event and turn off the flashing red LED on the end panel, which flashes a 2 blink pause repeating TCD code. The only other means of resetting the TCD code is by the NHRA tech-inspectors key, which is connected to the 8971 to inspect and/or reset the TCD event code that also sets the Rst 24.0Hrs counter to indicate the time elapsed from a KEY reset.

The Remote mounted LED's indicate to the crew chief or driver that both channels are properly reset when the reset is activated and the launch timer is running when the WOT switch is activated at the launch. The Red LED's will not illuminate if any alert code is flashing on either channel or if only one channel resets, indicating an alert condition exists, or one channel microcontroller is not operating. The reset function is activated when the reset switch is activated in the case of alerts blinking. The LED end panel should be visible to the crew chief when properly mounted in the car so that correct operation can be verified after the engine is started and when the reset is activated prior to launch.

The green LED's can be used to verify proper actuation of the WOT switch by illuminating after a reset when the WOT switch is closed supplying +12 volts to the dark blue wire of the 8971. When the throttle is lifted the green LED's should begin rapidly blinking to indicate the WOT switch is opened.